



# Operations Manual

# Table of Contents

Overview	1
Hardware Setup	2
Software Setup	3
SwiftMix™ Startup Sequence	4
Session Setup	6
Automation Modes	6
Fader Channel Assignment	8
SwiftMix™ DAW Select Mode	9
SwiftMix™ Self-Test Mode	10
SwiftMix™ MC-5 Transport Control	11
Service Instructions	15
Limited Warranty	16

## Introduction

Thank you for purchasing the SwiftMix™ automation system for your 5088 console. We hope you enjoy using this tool as much as we have enjoyed designing it. Please read through the entire manual before attempting to setup or operate your SwiftMix™ system.

## Overview

SwiftMix™ is designed to provide state-of-the-art motorized fader control for your DAW over Cat5e Ethernet protocol. This system combines the accuracy and convenience of digital automation with the unrivaled analog sound of the Rupert Neve Designs 5088 Console.

Each SwiftMix™ fader channel features five illuminating tactile switches along with a 100mm motorized fader. The switches control DAW channel selection, solo, mute, track record enable, and automation mode selection. The automation MODE switch toggles the selection between OFF, READ, TOUCH, LATCH, and WRITE, as indicated by LEDs on the fader panel. A carbon impregnated fader cap provides touch response while dampening any static discharge, and the 100mm fader is accurate to within 0.2mm for writing, adjusting, and following DAW automation commands.

For maximum compatibility, SwiftMix™ communicates over a 9-Bit HUI Ethernet protocol. SwiftMix™ provides precise fader-mapped calibration, allowing the motorized analog fader to be instantly matched to previously recorded DAW automation, thus drastically improving studio workflow with quick recall. After installing the ipMIDI driver on your DAW computer, system setup is accomplished by connecting a single Ethernet cable between the DAW host computer and the SwiftMix™ SMP-1. SwiftMix™ faders are preset with their intended fader slot locations, making it very simple to get the system up and running. SwiftMix™ has been optimized primarily for use with Avid ProTools and Apple Logic, however, it will work with most DAWs that support HUI control surfaces.

# Hardware Setup

1. Connect power to the SwiftMix™ SMP-1 Control Module.
2. Connect power to the included Ethernet Gigabit Switch and power on.
3. Disconnect any Ethernet (LAN) connections to your host DAW computer.
4. Disable any Wi-Fi connectivity to your host DAW computer.
5. Connect an Ethernet cable from your router (LAN) to the included Ethernet Gigabit Switch.
6. Connect a second Ethernet cable from the Ethernet Gigabit Switch to your host DAW computer.
7. Connect a third Ethernet cable from the SMP-1 to the Ethernet Gigabit Switch. A Thunderbolt to Ethernet adapter may be required for newer computers.
8. Connect the DB-37 cable between the 5088 console rear panel and the SMP-1.
9. Wait to power on the SwiftMix™ SMP-1 until after the Software and DAW setups are both complete.

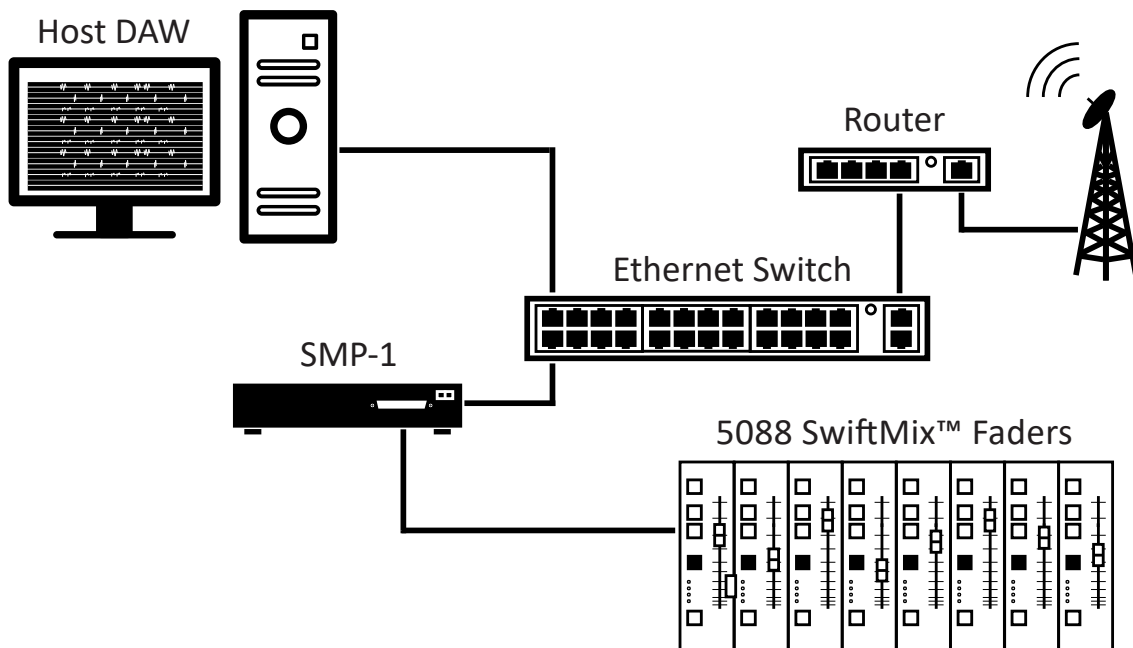

## Software Setup

In order for the host DAW computer to accept the HUI over Ethernet protocol, the midi driver ipMIDI must be installed on the host machine. Before DAW setup, visit the following address to download the ipMIDI driver, and install it on your host computer.

[www.nerds.de/en/download.html](http://www.nerds.de/en/download.html)

For Mac OSX 10.6 – 10.9, download and install ipMIDI v1.6

For Mac OSX 10.10 – 10.13, download and install ipMIDI v1.7

1. After following ipMIDI's installation procedure, locate the "Audio MIDI Setup" app and double-click to open. Applications > Utilities > Audio MIDI Setup
2. Once the Audio MIDI Setup window is open, press Command 2 to open the MIDI window dialog box. Locate the ipMIDI icon and double-click to open the port configuration window so that you can assign the correct number of ports for your Swiftmix™ system.
3. SwiftMix™ requires one port for every bank of eight SwiftMix™ faders. A 16-channel system requires 2 ports, and a 32-channel system requires 4 ports.
4. Wait until after the DAW Setup has been performed before powering on the SwiftMix™ SMP-1 system.

## ProTools DAW Setup

1. Open ProTools and click on the Setup tab in the menu bar, then open the Peripherals menu and click on the MIDI Controllers tab.
2. In the MIDI Controller #1 row, select:

Type: HUI

Receive From: Predefined ipMIDI, Port 1

Send To: Predefined ipMIDI, Port 1

# Ch's: 8

3. For the next bank of 8 SwiftMix™ faders, click on MIDI Controller #2, and select the following:

Type: HUI

Receive From: Predefined ipMIDI, Port 2

Send To: Predefined ipMIDI, Port 2

# Ch's: 8

For a 16-Channel system, you will need to assign MIDI Controller #1 and #2. For a 32-Channel system, you will need to assign MIDI Controller #1, 2, 3, and 4. After all SwiftMix™ faders have been properly mapped to their ports, click OK to accept the changes.

*Note: SwiftMix™ systems are currently limited to a maximum of 32-channels.*

4. Quit ProTools.

## **SwiftMix™ Startup Sequence**

1. Before booting up the SwiftMix™ system for the first time, make sure you have already completed the following steps:
  - a) Connected all necessary SwiftMix™ hardware connections.
  - b) Downloaded and installed ipMIDI to your host DAW computer.
  - c) Configured your ports in Audio MIDI Setup.
  - d) Configured port-mapping in ProTools Peripherals Menu .
2. Power on the SwiftMix™ SMP-1 and allow 1 minute to pass before opening your DAW software. If the initial connection is successful, the green LED in the SMP-1 Ethernet Jack should flash periodically. The orange LED in the SMP-1 Ethernet Jack should remain solid.

Upon initial SMP-1 bootup, all SwiftMix™ automation LEDs and tactile switch LEDs should turn on. After a moment, the tactile switch LEDs should turn off, only the automation mode LEDs should remain illuminated.

3. After 1 minute, open your DAW software. Once you have created a session and assigned tracks in your DAW software, the automation mode LEDs should link and reflect the proper DAW automation mode.

In ProTools, the default automation status should indicate READ mode.

4. At this point, check for proper operation:
  - Move a SwiftMix™ Fader to see if it moves the corresponding DAW Fader.
  - Move a DAW Fader and see if it moves the corresponding SwiftMix™ Fader.
  - Verify that all SwiftMix™ tactile switches trigger their corresponding functions in the DAW and vice-versa.

## Other DAWs

SwiftMix™ can be used with other DAWs, however the HUI setup procedure will be different, therefore the user should consult the DAW documentation for proper setup and installation. The ipMIDI driver will still need to be installed and assigned to the correct ports in Audio MIDI Setup.

## SwiftMix™ SMP-1 Control Module

Back Panel Connections:

RJ-45 Female Ethernet Jack  
IEC AC Power Inlet Receptacle

Front Panel Connections:

DB-37 Male Connector  
Illuminating Power Switch

## Session Setup

SwiftMix™ can be configured so that either the analog fader or the DAW fader affects the audio signal. For SwiftMix™ fader analog level control, set the faders to READ, TOUCH, or LATCH mode and set the DAW channel outputs to pre-fader.

In ProTools, this can be done by assigning a Pre-Fader Send on each ProTools track to the desired analog output on your interface. This way, the DAW fader will not alter the level of your audio interface's output send to the 5088 console. Instead, the SwiftMix™ fader will control the analog level to your mix buss at the console. This allows SwiftMix™ to function as it would on a typical console with fader automation.

Another option is to control your fader levels within your DAW by setting the automation mode to OFF, assigning the DAW outputs to corresponding channels on the 5088, and bringing all the SwiftMix™ faders to unity gain. This way, all the mixing and level control can be accomplished within the DAW.

## Automation Modes

The faders will work according to the mode selected by the user. Changing the automation mode on the SwiftMix™ fader will change the mode on the corresponding DAW track, and vice-versa.

### **OFF (All SwiftMix™ mode LEDs off)**

In this mode, the SwiftMix™ fader is completely manual. The DAW fader and SwiftMix™ fader will not follow DAW automation. Starting and stopping the DAW transport does not change the automation mode.

### **READ (SwiftMix™ READ mode LED on)**

In this mode, the DAW fader and Swiftmix™ fader follow automation. When a SwiftMix™ fader is moved, the DAW fader follows the user movements. Neither the DAW fader nor the SwiftMix™ fader movements are recorded into automation. Starting and stopping the DAW transport does not change the automation mode.



## TOUCH (SwiftMix™ TOUCH mode LED blinking or solid)

In this mode, if the transport is either stopped or running and the fader is not touched, the TOUCH mode LED blinks. The fader will follow previously recorded automation until it is touched, at which point it will begin overwriting any stored automation moves. When a SwiftMix™ fader is touched, the TOUCH mode LED becomes solid and the DAW fader follows user movements until the fader is released. Once released, the fader will return to following previously recorded automation.

## LATCH (SwiftMix™ LATCH mode LED blinking or solid)

In this mode, when the transport is either stopped or running and the fader is not touched, the LATCH mode LED blinks. The DAW fader and SwiftMix™ fader will follow previously recorded automation, until the fader is touched, at which point the previously recorded automation will be overwritten by the users movements. If the SwiftMix™ fader is released while the transport is still running, the LATCH mode LED will remain lit, and the current SwiftMix™ fader position will continue to be recorded in automation until the transport is stopped, at which point the LATCH mode LED will start blinking.

## WRITE (SwiftMix™ WRITE mode LED blinking or solid)

In this mode, when the transport is stopped and the fader is not touched, the WRITE mode LED blinks. When the transport is running but the fader is not touched, the WRITE mode LED illuminates solid and the current fader position is recorded into automation. When a SwiftMix™ fader is moved, the DAW fader follows, and is recorded into automation. When the transport is running and the fader is released, the WRITE mode LED remains illuminated, and the current fader position is written into automation. When the transport is stopped, the automation mode will generally revert to LATCH mode (this will vary based on DAW settings).

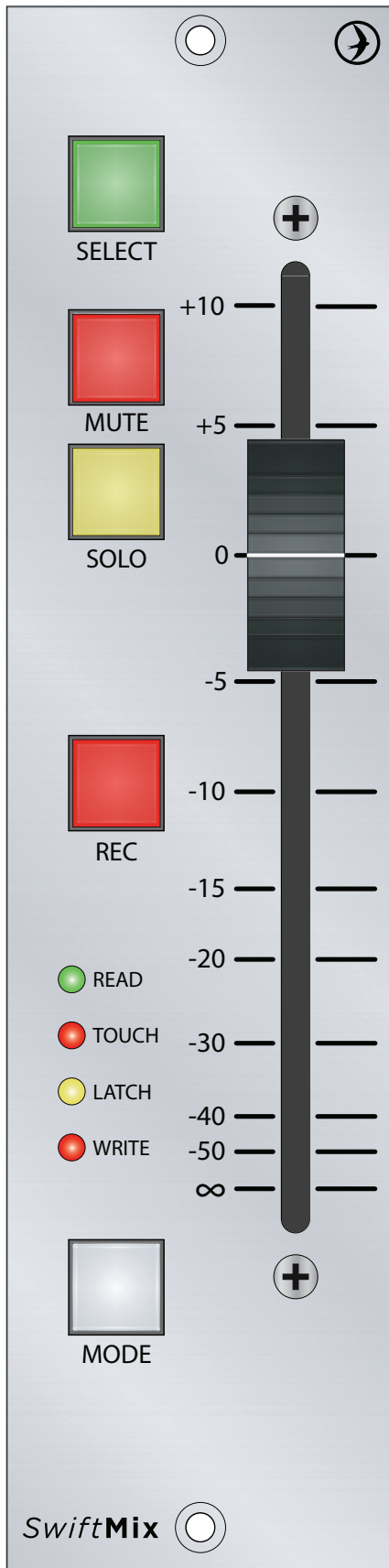

## Other DAW Controls

It is possible for other DAW controls and settings to modify SwiftMix™ performance. If other automation modes are enabled in the DAW, such as Pro Tool's TRIM mode, SwiftMix™ cannot be guaranteed to function correctly. In addition, using modifier DAW keystrokes when pressing channel select on a SwiftMix™ fader can trigger various functions in different DAWs, such as group selection or plug-in select. For more information, consult your DAW manual.

## Fader Channel Assignment

SwiftMix™ systems are grouped into banks of 8 faders. Each fader is pre-configured with its intended channel number. If faders are relocated, they will need to have their channel assignment dip switch settings modified accordingly. The channel below is configured as channel **one** in a bank of eight, with all dip switch settings in the OFF (up) position. A silkscreen legend next to the dip switch provides easy-to-read instructions for changing the settings.

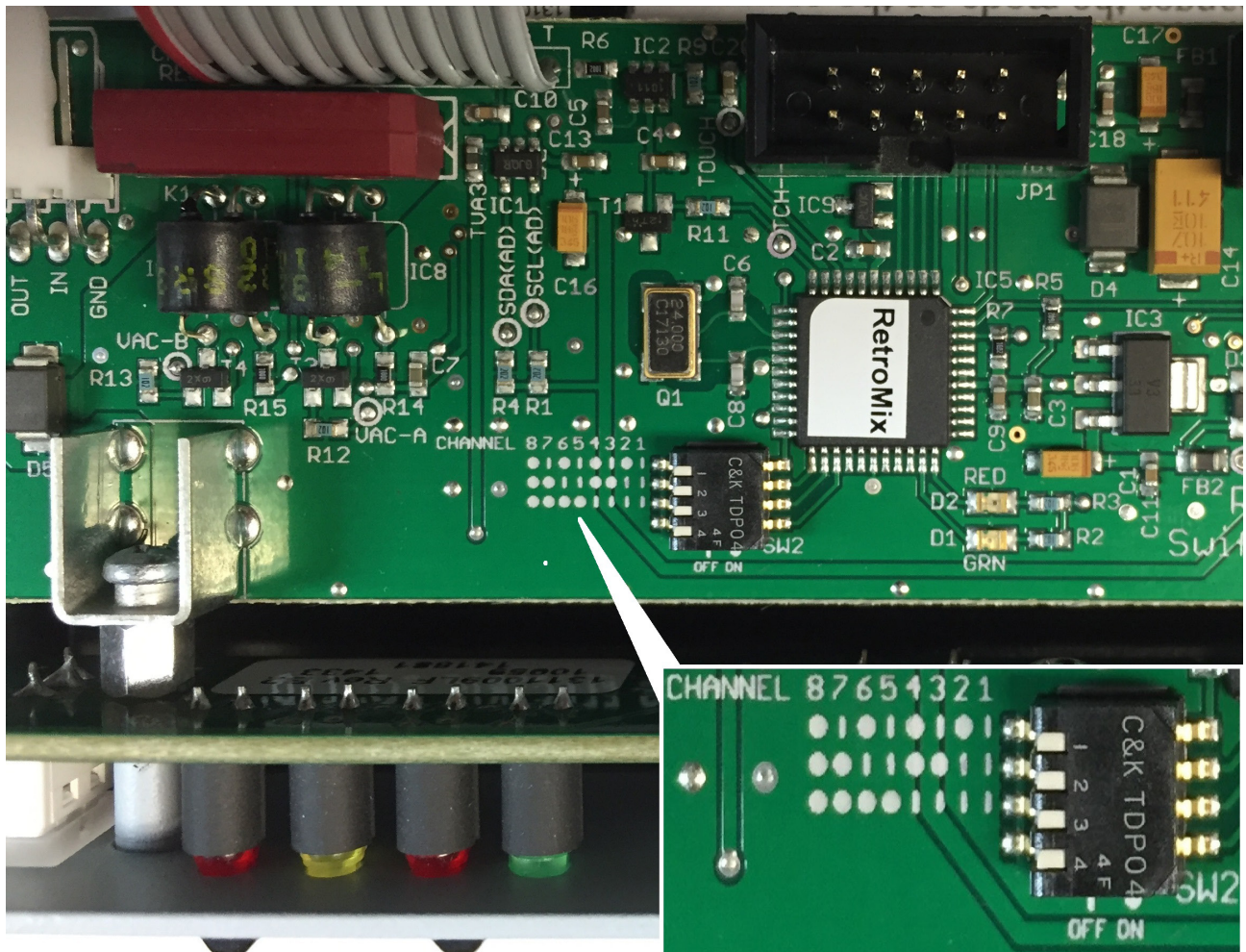

# SwiftMix™ DAW Select Mode

After setting up the SwiftMix™ hardware according to the setup instructions in this manual (page 2), power on the SMP-1.

On initial power up, all of the LEDs on each SwiftMix™ fader will illuminate.

*Note: There is no LED for the MODE button.*

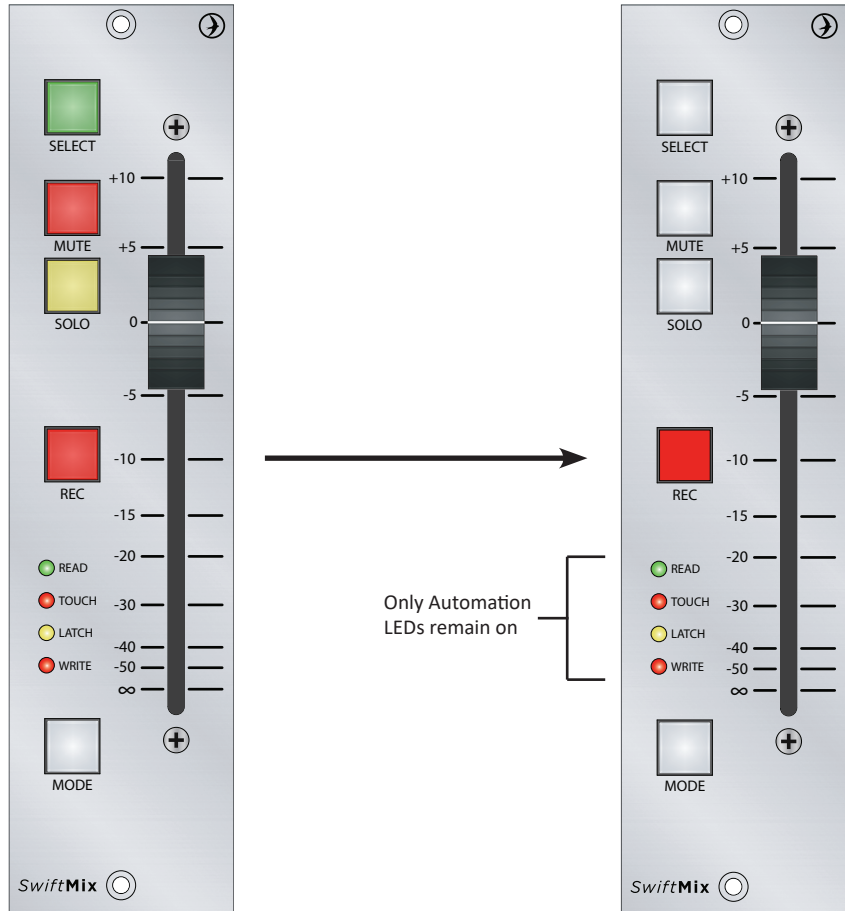

A few seconds after initial power up, the SELECT, MUTE, SOLO, and REC LEDs should turn off. The READ, TOUCH, LATCH, and WRITE automation mode LEDs should remain illuminated. At this point, the SwiftMix™ faders are in DAW select mode.

*Note: SwiftMix™ defaults to ProTools DAW select mode, indicated by all four automation mode LEDs illuminated.*

To toggle through different SwiftMix™ DAW modes, press and hold the Swiftmix™ Fader 1 SELECT button and press the MODE button to cycle through the three available DAW modes: ProTools, Logic, and Digital Performer.



**ProTools DAW Select** - All automation LEDs illuminated (Default startup)



**Logic DAW Select** - READ and TOUCH automation LEDs illuminated.



**Digital Performer DAW Select** - READ and LATCH automation LEDs illuminated.

## SwiftMix™ Self-Test Mode

To enter SwiftMix™ self-test mode, power on the SMP-1 and wait for the faders to enter DAW select mode. Press and hold SELECT on SwiftMix™ Fader 1 and then press the REC button on the same fader. All SwiftMix™ automation LEDs should turn off.

Press SELECT, MUTE, SOLO, REC, or MODE buttons on SwiftMix™ Fader 1 to confirm that the LEDs for each button are functional.

Press and hold the SELECT button on any fader and then press the MODE button to begin the servo motor self-test. Confirm that the faders automatically move to the top and bottom of their travel in unison.

Touch and hold each fader cap one at a time to override the servo motor on that fader to confirm that fader touch sense is working properly.

To exit the servo motor self-test, press and hold SELECT and press the MODE button on SwiftMix Fader 1. Finally, to exit Self-Test mode, press and hold the SELECT button and press the REC button to return to DAW select mode.

## SwiftMix™ MC-5 Transport Control

In an effort to further expand ProTools integration with the 5088 console, we have added the SwiftMix™ MC-5 Transport Control panel as part of our master section functionality for the SwiftMix™ system. With this addition, the engineer is given seamless control from the mix position, allowing for easy auditioning, decisive editing, and quick recall. These controls are meant to be familiar to a ProTools user, thereby dramatically decreasing the learning curve necessary to master this new feature set while simultaneously making it an intuitive, integral part of the 5088 SwiftMix™ system.

## SwiftMix™ MC-5 Startup Sequence

The startup sequence for a SwiftMix™ system with an MC-5 Transport is the same as for a regular SwiftMix™ system. If the initial connection is successful, the LOOP and STOP tactile switches on the MC-5 should light up once a ProTools session is open. For proper operation with ProTools, the user needs to configure the numeric keypad in “Classic” Transport Mode:

Setup > Preferences > Operation > Numeric Keypad: Classic

*Note: To run an MC-5 Transport section, you must have a minimum of eight SwiftMix™ faders.*

## Transport Section

*Note: The operational descriptions listed below are specifically related to ProTools. For other DAWs, please consult the DAW documentation for a description of functionality.*

**MARK** - Pressing this button once will bring up the “Memory Locations” dialog box, pressing it a second time will accept and drop the current “Memory Location” as indicated by the dialog box window.

**MODE** - Pressing this button repeatedly allows the user to cycle through the various ProTools editing window modes (Shuffle, Slip, Spot, Grid).

**TOOL** - Pressing this button repeatedly allows the user to cycle through the various ProTools editing tool modes (Zoom, Trim, Selector, Grabber, Smart, Scrubber, Pencil).

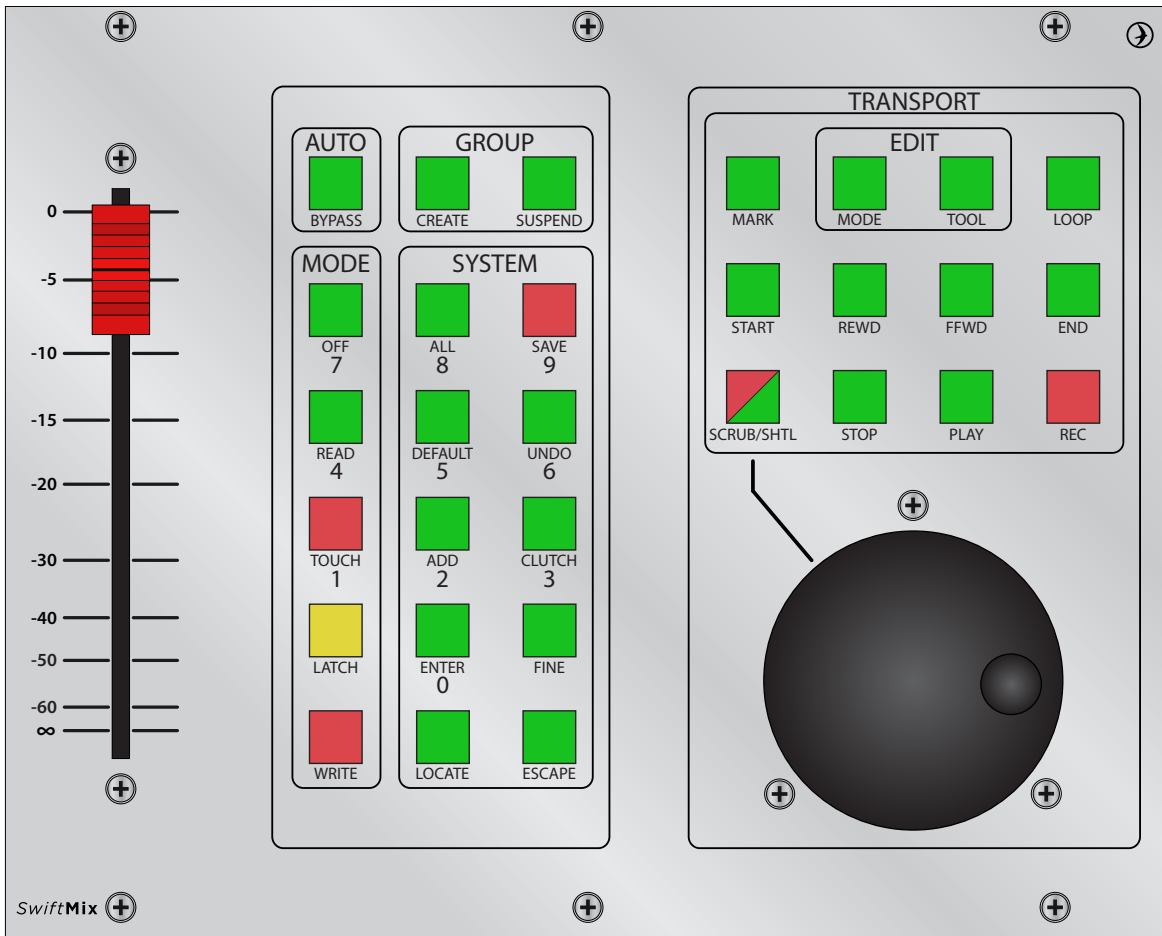

**LOOP** - Pressing this button toggles Loop Playback mode on and off.

**START** - Pressing this button moves the timeline cursor to the beginning of the ProTools session.

**REWD** - Pressing this button once will move the timeline cursor back by 1 bar increments. Pressing and holding this button will move the timeline cursor backwards until the REWD button is released.

**FFWD** - Pressing this button once will move the timeline cursor forward by 1 bar increments. Pressing and holding this button will move the timeline cursor backwards until the FFWD button is released.

**END** - Pressing this button moves the timeline cursor to the end of the ProTools session.

**SCRUB/SHTL** - Pressing this button once will enable SCRUB mode functionality for the jog wheel. Pressing and holding this button a second time will enable SHUTTLE mode functionality for the jog wheel. Pressing and holding once more will switch SHUTTLE mode back to SCRUB.

**STOP** - Pressing this button will stop ProTools from playing back.

**PLAY** - Pressing this button will start ProTools playback.

**REC** - Pressing this button will engage Record Enable on the ProTools transport. To successfully start recording, first Record Arm the desired SwiftMix™ fader, press REC (Record Enable) on the Master Transport, then press PLAY to start recording.

**JOG WHEEL** - This rotary encoder allows for scrub and shuttle control for auditioning purposes

## **Auto Section**

**BYPASS** - Pressing this button toggles global track automation bypass on and off.

## **Group Section**

**CREATE** - Pressing this button will open the Create Group dialog box to allow for the creation of ProTools groups. Pressing CREATE again will accept and close the current Group Dialog Box settings.

**SUSPEND** - Pressing this button will globally disable all current ProTools track groups.

## Mode Section

*Note: These automation mode buttons are intended to be used in tandem with the “ALL” button to globally switch between automation modes in ProTools.*

**OFF** - Pressing this button will globally disable all automated ProTools tracks.

**READ** - Pressing this button will globally switch all ProTools tracks to “Read” mode automation.

**TOUCH** - Pressing this button will globally switch all ProTools tracks to “Touch” mode automation.

**LATCH** - Pressing this button will globally switch all ProTools tracks to “Latch” mode automation.

**WRITE** - Pressing this button will globally switch all ProTools tracks to “Write” mode automation.

## System Section

**ALL** - Pressing and holding this button while simultaneously cycling through the available automation buttons allows for global switching of automation modes.

**SAVE** - Pressing this button will save the current ProTools session.

**DEFAULT** - Pressing and holding this button allows the user to zero the fader at unity gain. First, press and hold DEFAULT, then press the desired SwiftMix™ fader’s SELECT button to bring that fader to unity. Combining this with holding ALL allows an entire bank of ProTools faders to be brought to unity all at once.

**UNDO** - Pressing this button will undo as many actions as available in the ProTools session.

**ADD** - Pressing and holding this button while selecting tracks on SwiftMix™ faders allows for multiple tracks to be highlighted simultaneously. For example, if you wanted to highlight tracks 1-4, first press the SELECT button on the Track 1 SwiftMix™ fader, then hold ADD, then press the SELECT button on the Track 4 SwiftMix™ fader to highlight Tracks 1 – 4.



**CLUTCH** - Pressing and holding CLUTCH allows an individual SwiftMix™ fader to be temporarily unassigned from its corresponding group so that its relative level to the group can be adjusted individually. Once CLUTCH is released, the SwiftMix™ fader is once again part of its original group, but is now adjusted to its new relative level.

**ENTER** - Pressing this button will either open the memory locations dialog box, or it can be used to accept changes made in any ProTools dialog window (equivalent of clicking OK in ProTools).

**FINE** - Pressing and holding this button allows the user to access higher jog wheel resolution in SCRUB mode.

**LOCATE** - Press this button once to enter LOCATE mode, in which the numeric keys will light up. After pressing the locate button once, type in the number corresponding to the memory location that you want, then press LOCATE again to jump to that memory location.

**ESCAPE** - Press this button to exit any ProTools dialog window.

## Service Instructions

If you suspect a defect in your device, please contact our support staff for troubleshooting. If it is determined that the device is malfunctioning, we will issue a Return Material Authorization and provide instructions for shipping the device to our service department.

**Rupert Neve Designs, LLC**  
**Service and Support Department**  
**(512) 847-3013**  
**[service@rupertneve.com](mailto:service@rupertneve.com)**

## **Limited Warranty**

Rupert Neve Designs warrants this product to be free from defects in materials and workmanship for a period of three (3) years from date of purchase, and agrees to remedy any defect identified within such three year period by, at our option, repairing or replacing the product.

This warranty, and any other express or implied warranty, does not apply to any product which has been improperly installed, subjected to usage for which the product was not designed, misused or abused, damaged during shipping, damaged by any dry cell battery, or which has been altered or modified in any way. This warranty is extended to the original end user purchaser only. A purchase receipt or other satisfactory proof of date of original purchase is required before any warranty service will be performed. THIS EXPRESS, LIMITED WARRANTY IS IN LIEU OF ALL OTHER WARRANTIES, EXPRESS OR IMPLIED, TO THE EXTENT ALLOWED UNDER APPLICABLE STATE LAW. IN NO EVENT SHALL RUPERT NEVE DESIGNS BE LIABLE FOR ANY SPECIAL, INCIDENTAL, OR CONSEQUENTIAL DAMAGES RESULTING FROM THE USE OF THIS PRODUCT. Some states do not allow the exclusion or limitation of consequential damages or limitations on how long an implied warranty lasts, so this exclusion may not apply to you.

If you suspect a defect in this product, please call us at 512-847-3013 or contact our support staff ([service@rupertneve.com](mailto:service@rupertneve.com)) for troubleshooting. If it is determined that the device is malfunctioning, we will issue a Return Material Authorization and provide instructions for shipping the device to our service department.

## **Disclaimer**

Rupert Neve Designs, LLC has an established policy of seeking improvements to designs, specifications and manufacture of its products. Alterations to existing products take place continually, often without notice.

Despite considerable efforts to produce the most up to date information, this booklet should not be considered an infallible guide to the latest specifications available.